



Tabletop Single Head Pump Fillers

FILLERS

APACKS FRT-1000-AP Tabletop Single Head Pump Filler is designed for versatility while offering an economical, user friendly and high quality solution to satisfy low volume production needs.

By implementing true positive displacement filling, this Filler provides increased filling accuracy and reliability with products prone to viscosity change. Low viscosity (thin) to high viscosity (thick) liquids are capable of being filled with the pulse-based, stainless steel, Gear Pump.

The FRT-1000-AP offers rugged, portable and compact construction as well as a user friendly PLC Controls with touch screen HMI and tool-less fill height adjustment, plus many more standard features. Options are available for even more flexibility.

Tabletop Single Head Pump Fillers are used in the production of cosmetics, food and beverages, cleaning and specialty chemicals, pharmaceuticals, personal care and more.



SPECIFICATIONS

Standard Construction: Rugged, compact, portable design

Number of Fill Heads: 1

Filling Size: 1oz to 1gal

Power Requirement:
120VAC, single phase, 15 amp, 50-60Hz

Air Requirement:
2CFM @ 90PSI clean, dry, compressed air

Contact Parts: Stainless steel, Viton, Teflon, Carbon Shaft Seal, Ryton Gears

Dimensions & Weight:

- Length - 28.5" (724mm)
- Width - 15.25" (387.35mm)
- Height - 22.125" (562mm)
- Weight - 85lbs (39kgs)

Standard Features:

- Stainless steel Gear Pump with variable speed motor
- PLC Controls with touch screen HMI
- Foot Pedal
- Bottom-close Nozzles
- PVC Hose, good to 140 F degrees
- Tool-less fill height adjustment
- Plug-in Operation (120VAC/60Hz)

FILLERS

Tabletop Single Head Pump Fillers



OPTIONS

- Air-operated Ball Valve
- Product Supply Pump
- Lobe pumps for large particulate filling
- Special nozzles
- Custom applications
- Special electrical requirements
- Sanitary, hazardous, flammable and corrosive environment construction

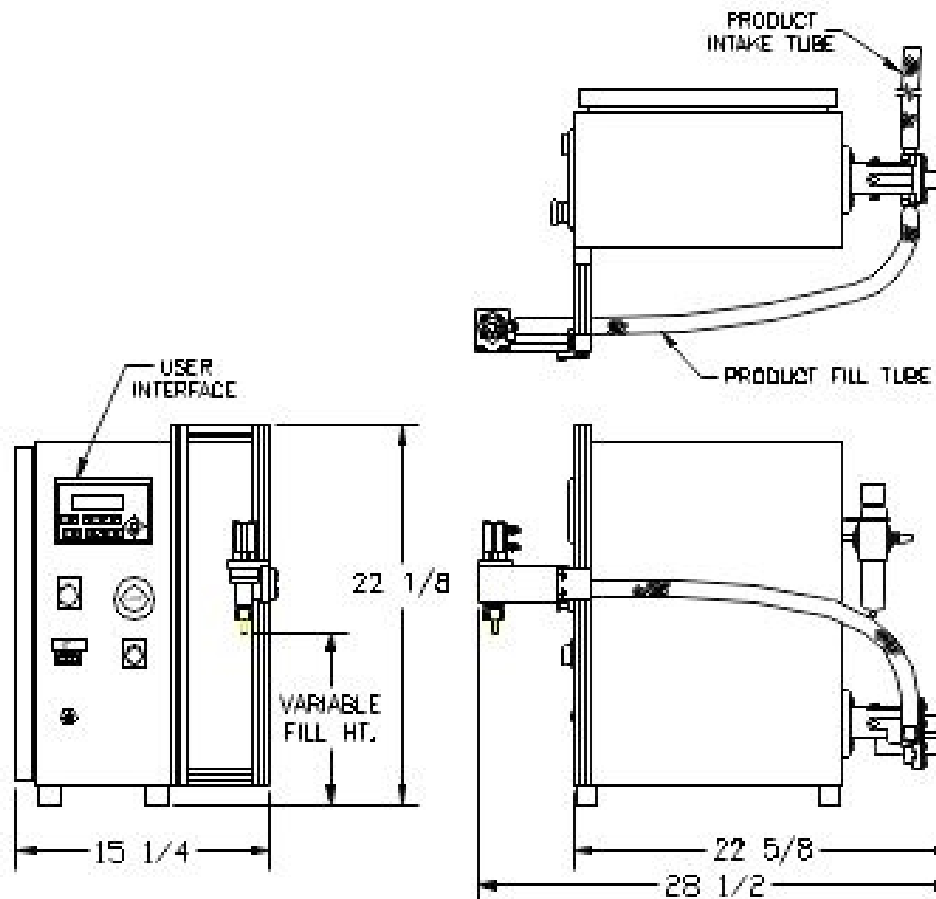

- **Complete line of filling and packaging solutions**
- **Standard filling machines in stock and ready to ship**
- **Economical prices, installation services and excellent customer service**

A PACKAGING SYSTEMS

1500 Lake Street, La Porte, Indiana 46350
Toll Free: 866-369-9030 Fax: 574-975-2711
sales@apackaging.com
www.apackaging.com

